

**DIEHL**  
Aviation

**ECO 16G**  
**PARTITION**  
**LIGHT, ROBUST**  
**AND RELIABLE.**

**DIEHL**  
Aviation

## SUSTAINABLE FEATURES



WEIGHT  
SAVING



CO<sub>2</sub>  
SAVING

## CHARACTERISTICS

The functionality of the new *ECO* 16G partition remains the same, but its weight has been reduced by another 10% to 15%, and its installation and integration in Airbus A320 aircraft have been improved. Through its monolithic design and rolled aluminium inlay, the partition's ability to withstand loads has also been improved once again. The partition can be installed in all known positions in the cabin and offers great flexibility in the configuration of optional items. Diehl Aviation's goal is to always offer its customers the best performance and sustainability in all products and services.

[diehl.com/aviation](https://diehl.com/aviation)

Diehl Aviation aims to contribute to the industry's goal of achieving net-zero aviation by utilizing lightweight, recycled, or bio-based materials to optimize resource consumption and reduce CO<sub>2</sub> emissions. These initiatives are at the core of the ECO efficiency product range.

## BENEFITS

- Reduced weight
- Increased stability
- Easier handling
- Very fast manufacturing
- Can be installed in all known positions in the cabin
- High flexibility in configuring optional items

## WHAT YOU GET

While the *ECO* 16G Partition looks simple in design, it is an intricately calculated, dimensioned, and machined piece of modern engineering technology. Here's what you get:

### 1 – Partition

Milled aluminum core for best weight and cost while offering premium stability and longevity.

- a) Main panel with milled chambers
- b) Cover plate thinned out for weight reduction

### 2 – Stretcher Flap (Option)

Smooth and easy removal through high precision milling

### 3 – Attachments

Maximum compatibility through reuse of existing attachment points.

- a) Upper tie-rod(s), 16 g double CAS capable
- b) Lower interfaces, for seat rails or fixed points

### 4 – Provisions

No surprises: everything you have & need today is there tomorrow. Additional provisions for CAS, emergency equipment etc. available to your needs.

- a) Edge panels for a unified cabin look & additional resilience
- b) Kick strips, long lived, damage resistant

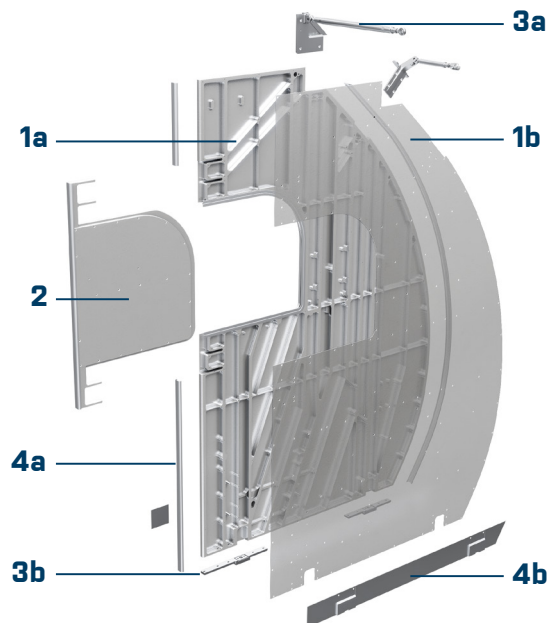

## SUSTAINABLE FEATURES\*



WEIGHT  
SAVING

Due to the new manufacturing technology with the optimized milled aluminum inlay the eco 16 g partition saves 10–15% in comparison to a state-of-the-art partition for this position. This is approx. 8 kg, assuming a baseline configuration.



CO<sub>2</sub>  
SAVING

Due to this weight saving, we can estimate a fuel saving of 1.1 tons per aircraft per year. This fuel saving can be converted into a saving of 3.3 tons CO<sub>2</sub> emission per aircraft per year.\*\*

Diehl Aviation aims to contribute to the industry's goal of achieving net-zero aviation by utilizing lightweight, recycled, or bio-based materials to optimize resource consumption and reduce CO<sub>2</sub> emissions. These initiatives are at the core of the ECO efficiency product range.

\*More Infos about the Sustainability Features you can find here:  
<https://www.diehl.com/aviation-highlights/en/eco-efficiency/>

\*\* estimated for a current generation single aisle aircraft e.g. A321, operating on medium range missions, e.g. Paris-Istanbul, with average operating hours of 3600 per year